

TROUBLE - SHOOTING

If you have followed the instructions carefully and your faucet still does not work properly, take the following corrective steps

PROBLEM	CAUSE	ACTION
Drain is leaking	Washers may be compromised or installed incorrectly	Check washers to make sure they are installed correctly and not cracked

KRAUS LIFETIME LIMITED WARRANTY

Kraus products are manufactured and tested to the highest quality standards by Kraus USA Inc. ("Kraus").

Kraus extends this warranty to the original purchaser for personal household use of the "**Bathroom Accessories**" in their original location. The warranty is non-transferable.

Kraus warrants the structure and finish of the product (**Bathroom Accessories**) to be free from defects in material and workmanship under normal usage for a period of one (1) year. The warranty commences from the initial date of purchase by the owner or trade professional, from an authorized Kraus dealer, through the lifetime of the original owner or end-user.

Any product reported to the authorized dealer or to Kraus as being defective within the warranty period will be repaired or replaced with a product of equal value at the option of Kraus. This warranty extends to the original owner or end-user, and is not transferable to a subsequent owner.

RESTRICTIONS

This warranty does not cover antediluvian, discontinued, or display products, whether such items are purchased at discount outlets, unauthorized dealers, and/or sold on clearance.

This warranty does not cover instances of negligence, misuse, abuse, improper installation, carelessness, accident, hard water or mineral deposits, exposure to corrosive materials, misapplication, damages caused by improper maintenance, alteration of the product, or failure to follow care or installation instructions enclosed with your product. Avoid using abrasive cleaners such as powders, bleach, ammonia, alcohol, or

chlorine. Avoid using abrasive pads, steel wool, or wire brushes, as these will damage and wear down the finish.

This warranty does not apply to Products that have not been installed or operated in accordance with instructions supplied by Kraus and all applicable rules, regulations, and legislation pertaining to such installations.

This warranty does not apply unless the Kraus product is installed by a fully insured and licensed trade professional. Kraus insists that such professionals have experience in the installation of bathroom and kitchen manufactured goods.

This warranty does not cover labor charges or costs of removal and reinstallation of said product. This warranty does not allow recovery of incidental or consequential damages such as loss of use, delay, property damage, or other consequential damages, and Kraus accepts no liability for such damages.

This warranty does not cover Marine or Outdoor Installation.

Except as otherwise provided above, Kraus makes no warranties, expressed or implied, including warranties of merchantability and fitness for a particular purpose, or compliance with any code.

Shipping charges will be covered for the first (1) year of the warranted replacement part or product (HI, AK, and Puerto Rico shipping charges may apply). International shipping fees are not included.

COMMERCIAL WARRANTY

Kraus extends the above warranty for a period of one (1) year to purchasers of products for industrial, commercial and business use.

All incidental or consequential damages are specifically excluded. No additional warranties, express or implied are given, including but not limited to, any implied warranty of merchantability or fitness for a particular purpose.

Some states do not allow the exclusion or limitation of incidental or consequential damages, or limitations on how long an implied warranty lasts, so the above limitations or exclusions may not apply to you.

This warranty gives you specific legal rights, and you may also have other rights which vary from state to state.

If you are a homeowner please contact a Kraus Customer Service Representative at:

Kraus USA, Inc.
12 Harbor Park Drive
Port Washington, NY 11050
Toll-free 800-775-0703
Customerservice@kraususa.com

If you are a plumbing contractor or trade professional please contact a Kraus Pro Representative at:

Kraus USA, Inc.
12 Harbor Park Drive
Port Washington, NY 11050
516-801-8955
Proservice@kraususa.com

If you are an Authorized Partner please contact a Partner Support Representative at:

Kraus USA, Inc.
12 Harbor Park Drive
Port Washington, NY 11050
516-801-8954
Partnersupport@kraususa.com

In requesting warranty service, please be ready to provide:

1. Proof of purchase.
2. A description of the problem.

Kräus®

INSTALLATION GUIDE

POP-UP DRAIN PU-11

Thank You For Purchasing Kraus

We would like to take this opportunity to thank you for your business with Kraus USA. It is our sincere hope that you are completely satisfied with your experience. We welcome any questions or comments you may have, and will be glad to assist you in the future.

For more information about Kraus products, please visit our website at:
www.kraususa.com

Please register your new Kraus product at the following web address in order to activate the warranty and receive the full benefit of customer support:

www.kraususa.com/registration

Sincerely,

Kraus Customer Service

Prior to Installation:

Make sure you have all necessary parts by checking the diagram and parts list.

If any part is missing or damaged, please contact Kraus Customer Service at 800-775-0703 for a replacement

Kräus®
www.kraususa.com

PU-11 DIAGRAM AND PARTS LISTS

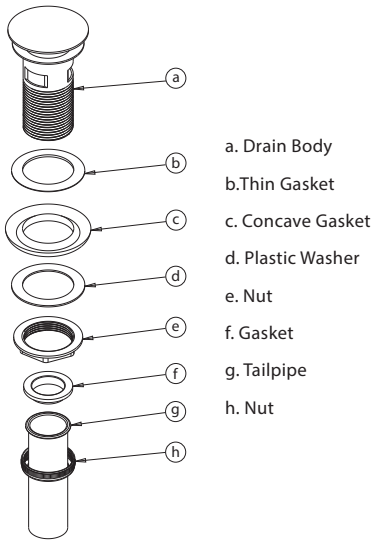

DIMENSIONS

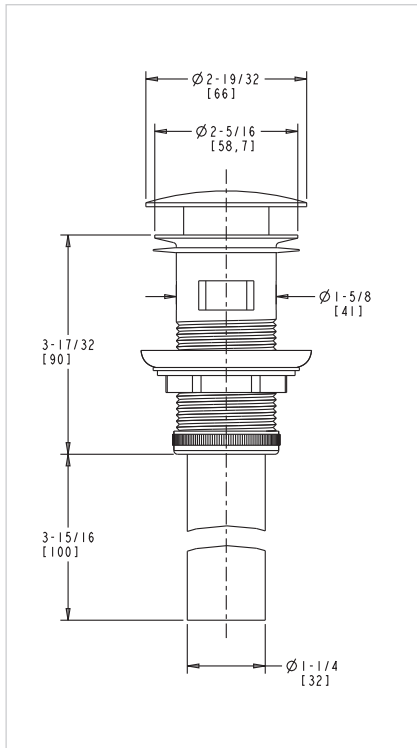

STEP 1

Remove connector (h), tail pipe (g), mounting nut (e), plastic washer (d), and concave washer (c) from drain body (a)

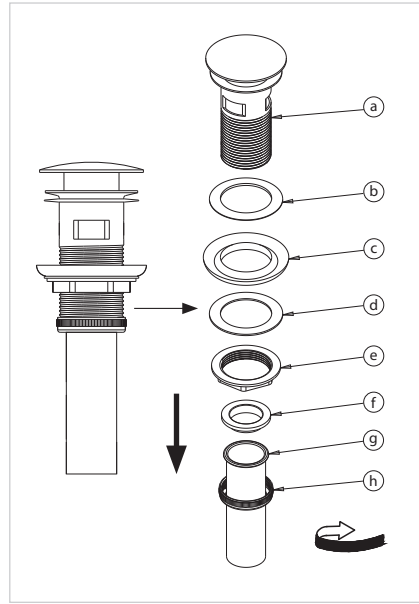

STEP 2

Install drain body (a), with rubber washer (b) attached, into the drain hole. From underneath, attach concave washer (c) (narrow end up), plastic washer (d), and mounting nut (e) to drain body (a)

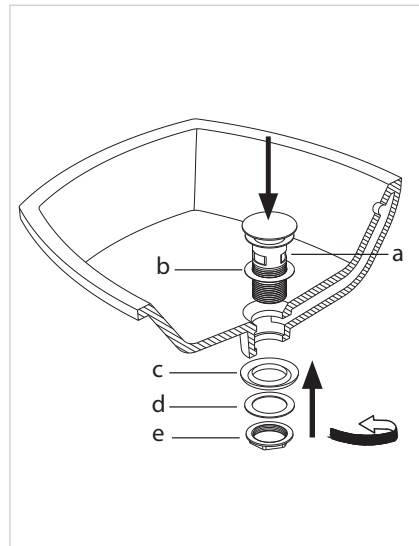

STEP 3

Tighten mounting nut (e) with adjustable wrench until snug. Thread connector (h), with tailpipe (g) attached, onto drain body (a) and hand-tighten

Installer Tip: Make sure tailpipe washer (f) is installed in tailpipe

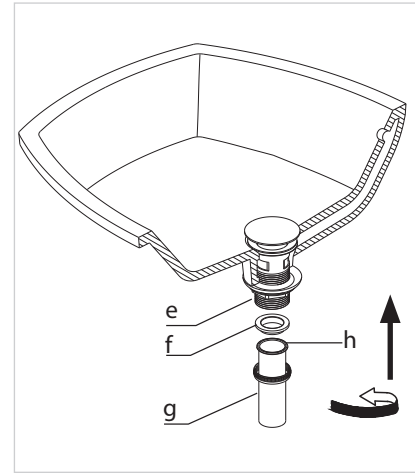

STEP 4

Connect tailpipe (g) to p-trap

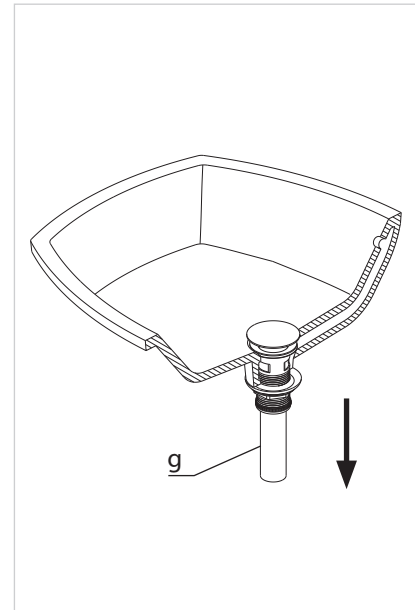

REPLACEMENT PART LIST

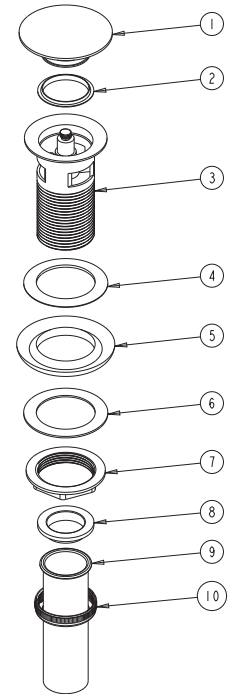

1. Drain Cap
2. Gasket
3. Drain Body
4. Thin Gasket
5. Concave Gasket
6. Plastic Washer
7. Nut
8. Gasket
9. Tailpiece
10. Nut

CARE & MAINTENANCE

* To keep the product clean & shining, follow the steps below:

1. Rinse with clean water & dry with a soft cloth
2. Do not clean with soaps, acid, polish, abrasives, or harsh cleaners
3. Do not use cloth with a coarse surface

* This installation manual is subject to change without notice