

Kräus®

INSTALLATION MANUAL

Britt™ Single Handle Commercial Style Kitchen Faucet

KPF-1691

Congratulations on the purchase of your new Kraus® plumbing fixture!

Please keep the box and packaging materials until your product is completely installed. If you have any questions, require technical assistance or have any problems with your product:



DO NOT RETURN TO STORE

**Please contact our Customer Service Team
1-800-775-0703 / customerservice@kraususa.com**

Have the model number available and retain a copy of your receipt with purchase date for reference.

If for any reason this product does not meet your expectations, please be sure to repack this product in the original box and packaging material to avoid damage during transit.

STOP

Prior to Installation:

- Make sure you have all necessary parts by checking the diagram and parts list. If any part is missing or damaged, please contact Kraus[®] Customer Service at 800-775-0703 for a replacement.
- Read all instructions and safety warnings and ensure you have all tools, parts, and equipment necessary for a safe installation.
- Turn off the hot and cold water supply at the angle stops and turn on the old faucet to release any built up pressure. Remove existing faucet.
- Pre-drilled hole size requirement: 1 3/8" (min)
- Max countertop thickness: 3 1/8"

For technical assistance or replacement parts, please contact Kraus Customer Service and one of our representatives will be happy to help:

Toll-Free: 800-775-0703 or Customerservice@kraususa.com

Tools Required



Care & Maintenance

- * To keep the product clean & shining, follow the steps below:
 1. Rinse with clean water & dry with a soft cloth
 2. Do not clean with soaps, acid, polish, abrasives or harsh cleaners
 3. Do not use cloth with a coarse surface
 4. Unscrew the aerator and clean when necessary
- * This installation manual is subject to change without further notice.



Faucet Dimensions

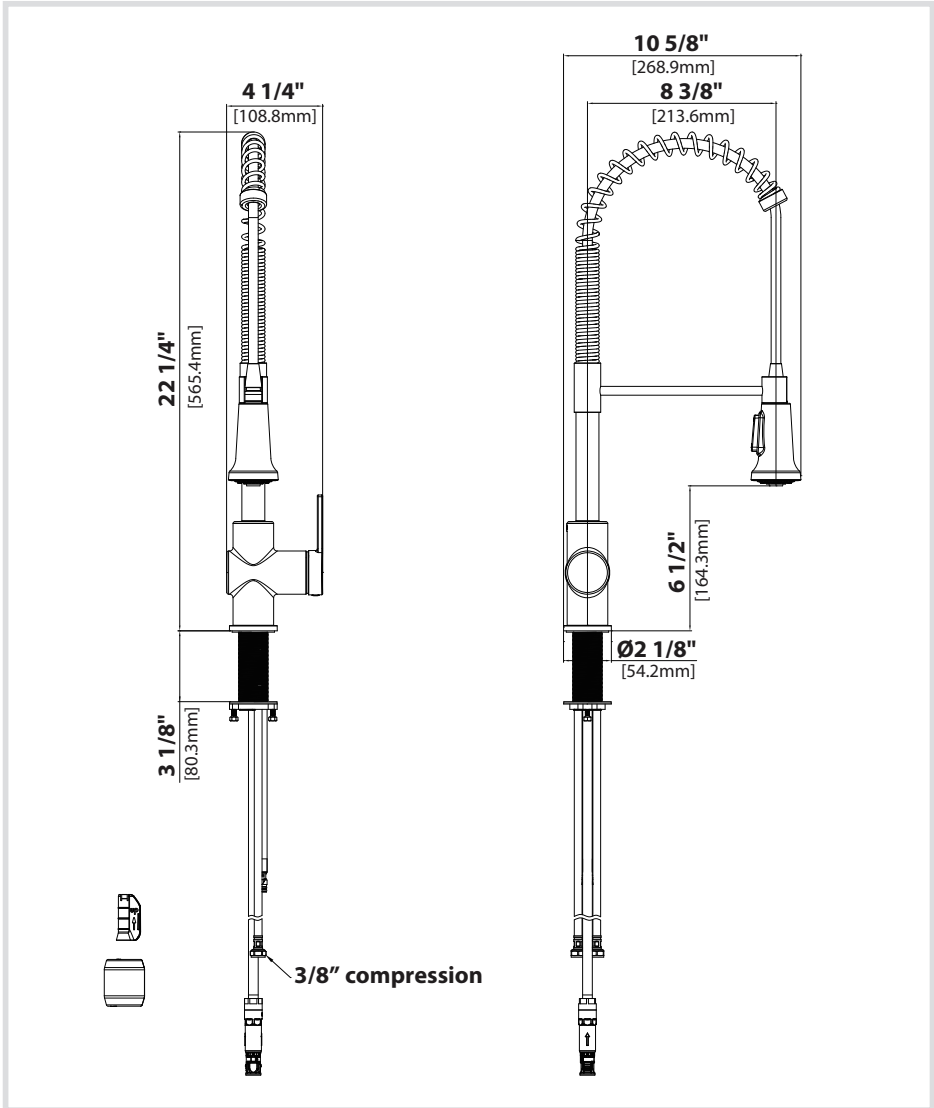

Installer Tip:

Shut off main water supply before installing new faucet.

Step 3: Securing the faucet assembly

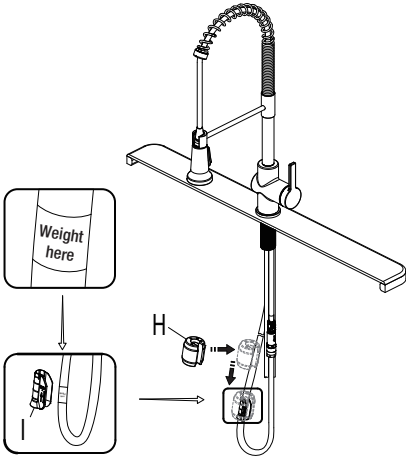

Install the weight clip (I) at the point of the hose marking "weight here". Insert the weight (H) onto the weight clip (I) by sliding it down onto the weight clip (I).

Step 4: Connect waterlines to main valve

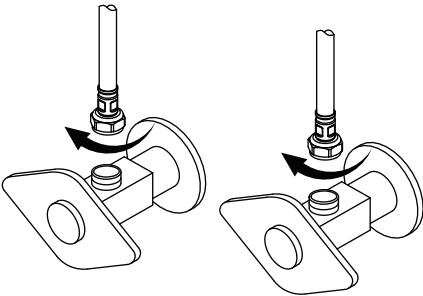

Attach waterlines to angle stops and tighten until snug. Turn on angle stops and check for leaks (DO NOT TURN FAUCET ON).

NOTE: Please make sure filter washers are installed before connecting to the main valve.

Step 5: Flush faucet

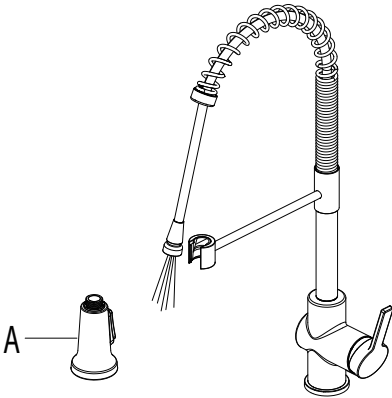

Pull the hose assembly out of the spout and remove the spray head (A) by unscrewing it from the hose in a counterclockwise direction. Be sure to hold the end of the hose down into the sink and turn the faucet on to the warm position where it mixes hot and cold water. Flush the water lines for one minute. This flushes away any debris that could cause damage to internal parts. Check for leaks. Retighten any connections if necessary, but do not overtighten. Reinstall the spray head (A) by hand tightening it back onto the spray hose.

After installation is complete, turn on the hot and cold water supplies. Check for leaks.

NOTE: Please make sure washer is installed attaching spray head to hose.

Replacement Parts

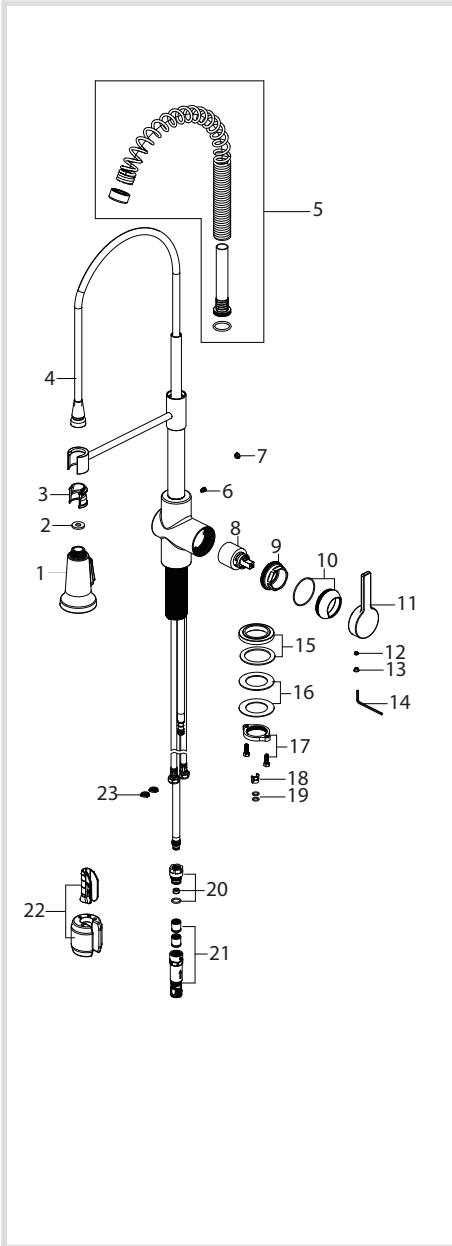

Replacement Parts List	Finish / Color	Part #
1. Sprayer Head	SFACB, BB, SFS,MB*	KP27195
2. Washer		KP27208
3. Inverter	BL, GR*	KP27242
4. Sprayer Hose	BLSFACB,GRSFS BLMB, BLBB,BLSFS*	KP27244
5. Spring Assembly	SFACB, BB, SFSB SFS,MB*	KP27243
6. Screw		KP27084
7. Index	BL, GR*	KP27124
8. Cartridge		KP27083
9. Bonnet Nut		KP27238
10. Cap & O-ring	SFACB, BB, SFSB SFS,MB*	KP27239
11. Handle	SFACB, BB, SFSB SFS,MB*	KP27240
12. Screw		KP27001
13. Index	BL, GR*	KP27002
14. Hex Wrench		KP27020
15. Flange & Washer	SFACB, BB, SFSB SFS,MB*	KP27041
16. Rubber & Metal Washer		KP27028
17. Mounting Nut & Screw		KP27079
18. Block		KP27073
19. O-Ring		KP27092
20. 1.8GPM Flow Restrictor	WHITE	KP27074-WH
21. Quick Connector Assembly		KP27090
22. Weight & Clip Assembly		KP27212
23. Filter Washer		KP27167

*Denotes faucet component color options:

SFACB - Spot Free Antique Champagne Bronze; GR - Grey; BL - Black; SFSMB - Spot Free Stainless Steel/Matte Black
 SFS - Spot Free Stainless Steel ; MB - Matte Black; BB - Brushed Brass; MBSFSB - Matte Black/Spot Free Black Stainless
 Black hose with Spot-Free Antique Champagne Bronze (BLSFACB); SFSB - Spot Free Black Stainless
 Black hose with Brushed Brass (BLBB); Black hose with Matte Black (BLMB);
 Grey hose with Spot Free Stainless Steel (GRSFS); Black hose with Spot Free Stainless Steel (BLSFS)

Troubleshooting

If you have followed the instructions carefully and your faucet still does not work properly, take the following corrective steps:

PROBLEM	CAUSE	ACTION
Leakage under the handle	Bonnet nut (9) has come loose	Remove the index (13). Loosen screw (12) with hex wrench (14). Remove the handle (11). Unscrew cap (10) (by hand only). Tighten bonnet nut (9) with an adjustable wrench
The aerator has an irregular or reduced water flow	The aerator is dirty or mis-fitted	Remove the aerator and check for debris. Ensure that the rubber washer is properly installed.
Water will not shut off completely	Cartridge may need to be adjusted or replaced	Remove the index (13). Loosen screw (12) with hex wrench (14). Remove the handle (11). Unscrew cap (10) (by hand only). Tighten bonnet nut (9) with an adjustable wrench. Remove the cartridge (8). Check for cracks
There is leaking from the sink drain at the base of the sink.	The sink has a rough or irregular surface.	Apply additional silicone sealant to the beveled side of the drain flange. Retighten and test for leaks
There is a low flow of water.	The filter washer in the hose connectors is dirty.	Turn off the water supply at water valve and unscrew the hose connectors from water supply lines. Clean the filter washer in the water lines with hot water, removing any debris or calcium build up

Codes/Standards Applicable:



Faucet - Lifetime Limited Warranty

Kraus® USA Plumbing, LLC ("Kraus") extends this warranty to the original purchaser for personal household use of the Faucet when purchased from an authorized Kraus dealer and in the location of original installation. This warranty is non-transferable.

Kraus warrants the structure and finish of the Faucet to be free from defects in material and workmanship under normal usage for as long as the original purchaser resides in the residence in which the Faucet was first installed.

Kraus warrants the Faucet's sprayhead assembly (including the engine, aerators, structure, restrictors, back flow preventers, sprayer hoses, braided supply line hoses which encompasses nylon, silicon and stainless steel) of the product to be free from defects in material and workmanship under normal usage for a period of one (1) year from the date of purchase.

Kraus warrants the Faucet's cartridge to be free from defects in material and workmanship under normal usage for a period of five (5) years from the date of purchase.

Any product reported to the authorized dealer or to Kraus as being defective within the warranty period will be repaired or replaced with a product of equal value at the option of Kraus.

Commercial Warranty

Kraus USA Plumbing, LLC ("Kraus") warrants its Products for a period of one (1) year to commercial purchasers of Products used in industrial, commercial and business applications.

Care and Cleaning Instructions

Certain cleaning products may cause damage to a Product's finish and use of the following on the Product will void this warranty:

- Abrasive cleaners such as powders, bleach, ammonia, alcohol or chlorine
- Abrasive pads, steel wool or wire brushes

What is Not Covered

This warranty does not cover Products that were discontinued when purchased or display Products, whether such Products were purchased at discount outlets, unauthorized dealers, and/or sold on clearance. This warranty does not cover any free gifts included with purchase.

This warranty does not cover damage resulting from neglect, misuse (including use for an unintended application), abuse, carelessness, accident, hard water or mineral deposits, exposure to corrosive materials, improper maintenance, alteration of the Product, or failure to follow care, cleaning or installation instructions enclosed with your Product. Kraus recommends that all Kraus Products be installed by a fully licensed and insured trade professional with experience in the installation of bathroom and/or kitchen manufactured goods.

How to Make a Warranty Claim

If you are a **consumer purchaser**, please contact a Kraus® Customer Service Representative at:
Kraus USA Plumbing, LLC
12 Harbor Park Drive
Port Washington, NY 11050
Toll-free 800-775-0703
Customerservice@kraususa.com

If you are a **plumbing contractor or trade professional**, please contact a Kraus Pro Representative at:
Kraus USA Plumbing, LLC
12 Harbor Park Drive
Port Washington, NY 11050
516-801-8955
Proservice@kraususa.com

If you are an **authorized partner**, please contact a Partner Support Representative at:
Kraus USA Plumbing, LLC
12 Harbor Park Drive
Port Washington, NY 11050
516-801-8954
Partnersupport@kraususa.com

In requesting warranty service, please be ready to provide your proof of purchase and a description of the problem. Shipping charges will be covered for the first (1) year of the warranted replacement part or product (HI, AK, and Puerto Rico shipping charges may apply). International shipping fees are not included.

Limitation on Duration of Implied Warranties

Please note that some states/provinces (including Quebec) do not allow limitations on how long an implied warranty lasts, so the below limitations may not apply to you. TO THE MAXIMUM EXTENT PERMITTED BY APPLICABLE LAW, ANY IMPLIED WARRANTY, INCLUDING THE IMPLIED WARRANTIES OF MERCHANTABILITY AND OF FITNESS FOR A PARTICULAR PURPOSE, IS LIMITED TO THE STATUTORY PERIOD OR THE DURATION OF THIS WARRANTY, WHICHEVER IS SHORTER.

Limitation of Special, Incidental or Consequential Damages

Please note that some states/provinces (including Quebec) do not allow the exclusion or limitation of special, incidental or consequential damages, so the below limitations and exclusions may not apply to you. TO THE MAXIMUM EXTENT PERMITTED BY APPLICABLE LAW, THIS WARRANTY DOES NOT COVER, AND KRAUS USA PLUMBING, LLC SHALL NOT BE LIABLE FOR, ANY SPECIAL, INCIDENTAL OR CONSEQUENTIAL DAMAGES (INCLUDING LABOR CHARGES TO REPAIR, REPLACE, INSTALL OR REMOVE THIS PRODUCT), WHETHER ARISING OUT OF BREACH OF ANY EXPRESS OR IMPLIED WARRANTY, BREACH OF CONTRACT, TORT, OR OTHERWISE.

This warranty gives you specific legal rights, and you may also have other rights which vary from state/province to state/province.

Download the Kraus Care & Maintenance Guide at:
<http://www.kraususa.com/maintenance>

IMPORTANT

Register Your Kraus Product

Activate Your Warranty

Access Premium Customer Support

Get Product Information

REGISTER TODAY

<http://www.kraususa.com/registration>



Kräus[®]
www.kraususa.com