

KCL-1700

32 Inch Undermount Single Bowl Stainless Steel Kitchen Sink Set

Kräus®

SPECIFICATION SHEET

Included with Set

Kitchen Sink KA1US32B
Kitchen Faucet KPF-1610SFS
Strainer ST-1
Drain Cap STC-2
Bottom Grid BG3017

Sink Features

- 16 Gauge Stainless Steel Construction
- Single Bowl Undermount Sink
- Required Minimum Cabinet Size: 36" Left to Right, 24" Front to Back
- Rear Center-Set Drain
- 3 1/2" Drain Opening
- NoiseDefend Undercoating and Sound Dampening Pads

Faucet Features

- Commercial Style Pull Down Faucet
- Metal Body
- Lead Free Braided Nylon Waterway
- 180° Swivel Spout
- Flow Rate: 1.8 gpm (6.8L/min) @ 60 psi
- Dual Function Sprayhead - Spray/Stream
- Silicone Nozzles
- 35mm Ceramic Cartridge
- 26.5" Integrated Nylon Waterlines
- Dome Shaped Screen Washer
- Quick Weight
- Quick Connect Sprayer Hose
- 16" Hose Length
- Connections 3/8" Compression
- Max Deck Thickness: 1 1/2"

Strainer Features

- Premium Stainless Steel construction
- Fits Standard 3 1/2" or 4" Drain Opening
- Open/Close Stopper Prevents Debris from Clogging Drain Pipe

Drain Cap Features

- Premium Stainless Steel Construction
- Fits Standard 3 1/2" Drain Opening
- Allows Water to Drain Easily When Installed
- Conceals Garbage Disposal and Waste Fittings for a Seamless Look

Bottom Grid Features

- Commercial grade stainless steel construction
- Protects bottom of sink from daily wear and tear
- Rubber feet provide additional protection

CODES/STANDARDS:

Sink Certification

cUPC (ASME A112.19.3/CSA B45.4), MASS

Faucet Certification

ASME A112.18.1/CSA B125.1
ADA compliant

Warranty

Kraus Limited Lifetime Warranty
see website for details www.kraususa.com

Kraus USA Plumbing LLC Customer Service
1.800.775.0703 | customerservice@kraususa.com

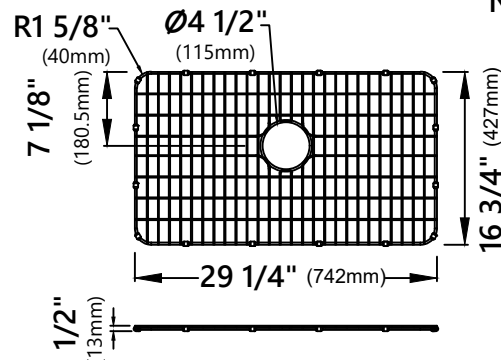
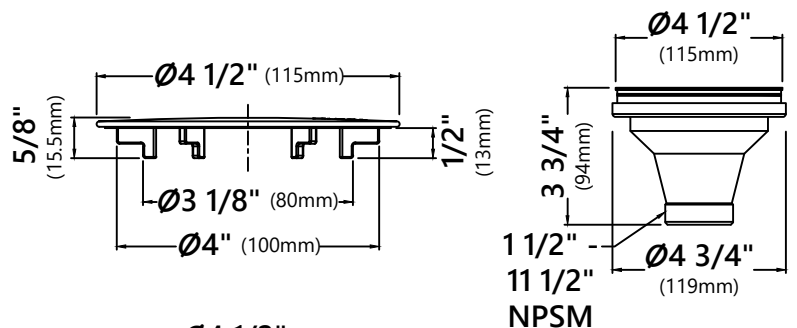
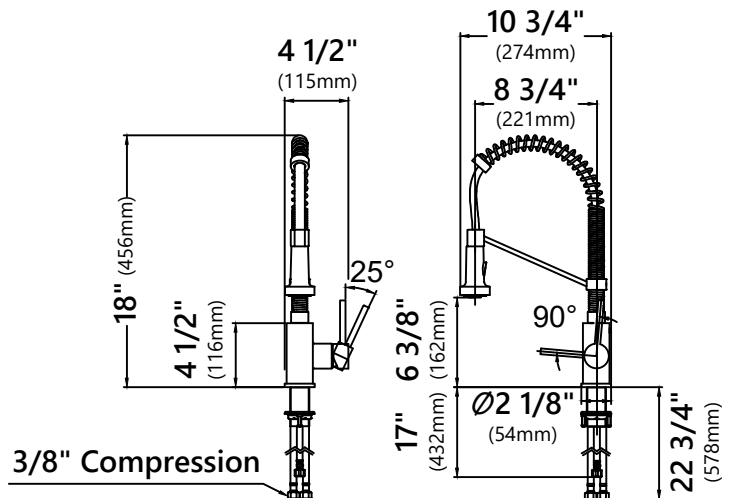
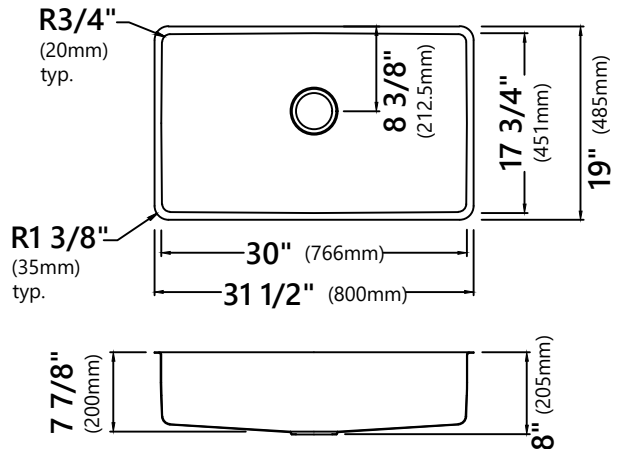

REV. October 24, 2023